

G680: Treadmill LK6800

Detailed Technical Specifications

Running area (LxW)	55 x 160 cm (22" x 63")
Motor	5.0 HP AC
Tilt	0 - 15 % (up to 17% with the optional kit "Incline +")
Speed	0.8-25 km/h
Maximum user weight	180 kg / 397 lbs.
Heart rate monitoring	Pulse sensors at handlebar and Polar telemetric heart rate monitoring
Programs	28 exercise profiles, manual program, customizable user program, Woman Fitness test, Man Fitness Test and HRC program (Heart Rate Constant frequency program)
On-screen information:	Speed, Distance, Time, Calories, Pulse rate, Inclination, exercise profile
Emergency Stop	Emergency Stop Button at front Toolbar and automatic stop system MOB (string)
Accessories	Double holder for bottles, keys, etc., jack connection for mp3.

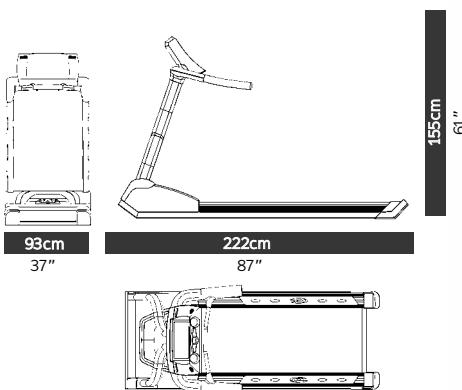

G680: Treadmill LK6800

- **Quiet, reliable 5.0 HP AC motor** produces speeds of between 0.8 and 25 km/h with maximum silence. It guarantees power and durability with minimum consumption, thanks to a more efficient use of energy, which leads to a lower consumption for the same performance.
- **Smart impact absorption system**, for more fluid running, as it controls and absorbs the force of each step on the board, helping to maintain a constant speed during exercise.
- **Progressive damping elastomers**. Its advanced technology elastomers gently absorb the first impact of the foot and harden the damping as users bend and lift their foot from the platform. This ensures correct damping that prevents joint and muscle pain in the knees and feet.
- **Powerful central elevation system of up to 17%**: An axle permits a maximum inclination of 15% in the standard model and up to 17% in models with the optional "Incline +" kit.
- **Aluminium lateral profiles with non-slip surfaces**, which help to prevent slips and falls during exercise.
- **NO lubrication**: Includes a revolutionary combination of belt and deck with a HST Phenolic wax unique in the market that provides a low maintenance system, and eliminates the need of lubrication for an estimated period of 6 months or 1 year (depending on the environmental conditions of the room and the frequency of use).
- **Painted ABS plastic casing**, using automobile technology.
- **Connection for mp3 and built-in speakers**, which let the user listen to their own music while exercising.
- **Band with tough, flexible, slip resistant, absorbent PVC surface**. This surface is highly resistant to abrasion, mechanical strength and shock proof and it is also recyclable.
- **Wheels**, for easy transportation and adjustable feet, **which ensure maximum stability**.
- **Monitored heart rate**: measured either by contact with the handlebar or via telemetry (Integrated POLAR compatible receiver).
- **Easy Toolbar for quick, instant access built into the front handrail**, this includes pulse rate contact sensors, one-finger speed and tilt buttons and emergency stop.
- **Programs**: Manual, 7 preset profiles with 4 different levels of difficulty and intensity each, user programmable profile, Man Fitness Test, Woman Fitness Test, and Heart Rate Constant program.
 - Heart Rate Constant program (HRC). Allows cardiovascular zones to be targeted during exercise. Automatically controls workout intensity to maintain effort at selected pulse limits.
 - Man/Woman Fitness Test. Allows to evaluate the shape and physical condition of the user.
 - Customizable user program. Allows to customize and configure your own training profile.



G680: Treadmill LK6800

- Two monitor option:

1 **Smart Focus Monitor TFT capacitive Touch Screen of 16 "HD**, besides of showing the evolution and training information (Speed, Time / Distance (km) Calories / Incline, Pulsation in watts, resistance, pulse, etc.), allows full connectivity to social networks, internet, television and applications thanks to the FitFeel interface that provides the fastest touchscreen technology of the market. With Smart Focus you can also customize the monitor, interact with users and customize workouts thanks to its Log in system for each user where they can save all the information of their workouts.

- USB port.
- Smartphones and iPods compatibility.
- Bluetooth Connectivity.
- CSAFE port.

2 **LED Monitor: DOT MATRIX screen with top LED window** that graphically displays the progress of the exercise. The bottom alphanumeric display gives the user instructions before and during the exercise. The 4 LED windows at the very bottom simultaneously show information for Speed, Time/Distance, Calories/Tilt and Pulse rate.

