

**VIBRATORY PLATFORMS YV30R Vibroboost GS**

**Give your guests the latest fitness trend!**

Install the latest fitness trend in your fitness area for a minimum outlay.



VIBROBOOST MONITOR WITH GRAPHICS DISPLAY



MULTIPOSITION HYPOALLERGENIC HANDLEBAR



**New GSR Graphics Monitor!  
100% Intuitive**

	<b>SELECT</b> <small>seleccione sélectionnez selecionar</small>
	<b>QuickStart</b>
	<b>Manual</b>
	<b>Beginner</b> <b>Medium</b> <b>Advance</b>

**1** Select the level

<b>STRENGTH</b> <small>fuerza • force • força</small>
<b>MASSAGE</b> <small>masaje • massage • massagem</small>
<b>STRETCHING</b> <small>estiramientos • étirements • alongamentos</small>
<b>OLDER PEOPLE</b> <small>mayores • âgées • idosos</small>

**2** Select the type of exercise

0 S	L	45Hz
<b>SELECT MUSCLES</b> <small>seleccione músculos</small>		
<small>sélectionnez muscles selecionar músculos</small>		

**3** Select the part of the body you want to work

45S	L	45Hz
<b>SELECT EXERCISE</b> <small>seleccione ejercicio</small>		
<small>sélectionnez exercice selecionar exercicio</small>		

**4** Select the position

0 S	L	45Hz
<b>SELECT EXERCISE</b> <small>seleccione ejercicio</small>		
<small>sélectionnez exercice selecionar exercicio</small>		

**5** Select the time

**START**

**6**

## VIBRATORY PLATFORMS YV30R Vibroboost GS

- **Triaxial vibration**; makes it easier to eliminate “cellulitis” or get an intensive workout
- **Maximum user weight**: 150 kg / 331 lbs.
- Equipped with **2 powerful 200 W AC motors**.
- **Control panel located halfway up the main column** that makes easier to do floor exercises.
- 50 x 70 cm / 20 x 27.3” **vibration plate** for a comfortable use.
- **Made of fibre glass**; sturdy structure and easy transportation
- **GSR Graphics display**. Functions:
  - **Multiple programs to exercise each part of the body in a very simple and intuitive way**
  - **Frequency**: 30, 35, 40 and 45 Hz.
  - **Amplitude**: Low: 1 to 2 mm. / High: 3 to 4 mm.
  - **Time**: 30-90 seconds
- **Central grip handlebar (hypoallergenic)** for greater comfort and headrest for seated exercises.
- Including **fitness mat** for floor exercises and a 10 mm thick yoga mat for greater comfort, especially for exercises that require upper limb, hip or buttock
- Includes belts for exercising upper extremities and **training guide**.
- **Wheels** for transportation.

### Measures

**Product line:** Group classes  
**Family:** Vibratory Platforms

**Weight:** 71 Kg. / 155 lbs.  
**Max. user weight:** 150 Kg. / 331 lbs.  
**Height:** 140 cm. / 54.6 “  
**Width:** 70 cm. / 27.3 “  
**Length:** 70 cm. / 27.3 “

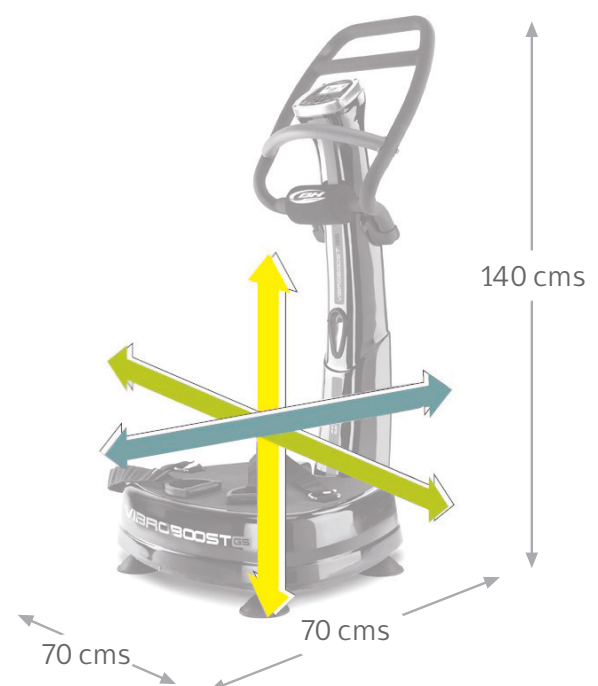

**TRIAxIAL VIBRATION**